

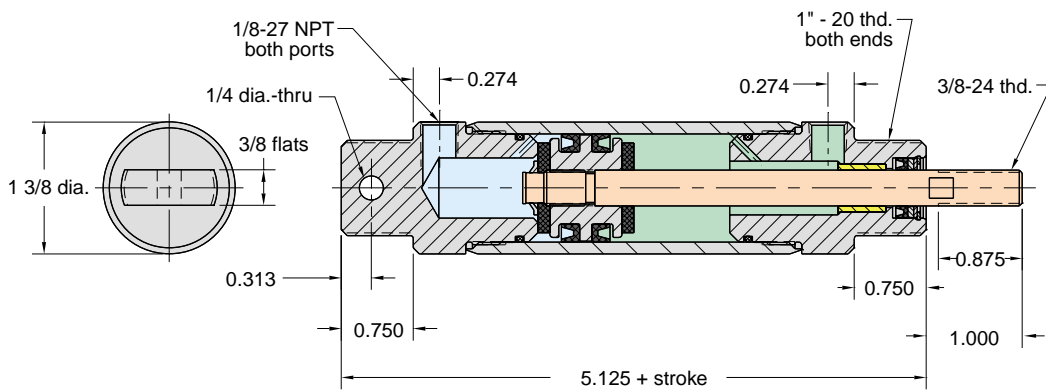

1 1/8" BORE HEAVY DUTY ALUMINUM CYLINDER

Features

- Very low breakaway force - allows for a consistent stroke speed (no sudden jumps)
- Hard-anodized aluminum body - attractive, yet durable
- Force factor of 1 - 100 psig input provides 100 lbs. output force
- Available in many stroke lengths (even up to 8 ft. in special quantities!)
- Brass piston, stainless steel rod



18SS-1

Mount: Stud

Available Stroke Lengths: 1"

Type: Single Acting
Spring Return

Add **-N** to the end of the part number for a non-threaded rod

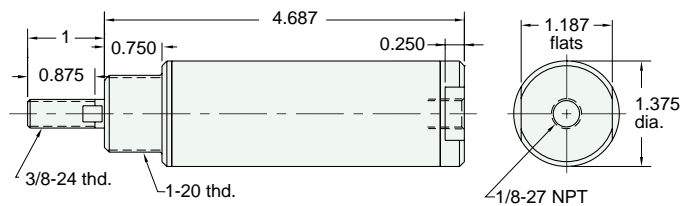

Nut included, but not shown on drawing

18S-1

Mount: Universal

Available Stroke Lengths: 1"

Type: Single Acting
Spring Return

Add **-N** to the end of the part number for a non-threaded rod

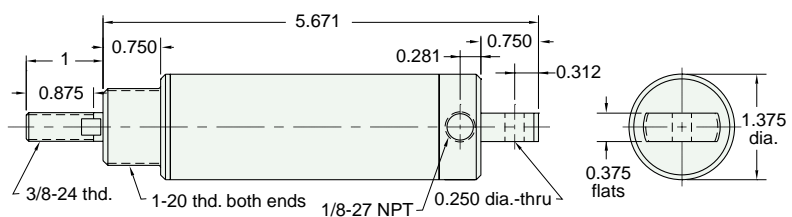

Nuts included, but not shown on drawing